



Instructions for: 19700 SERIES INVISIBLE LADDER

12.627

Thank you for selecting our superior quality Garelick EEz-In Brand Boarding Ladder. Your ladder is designed and manufactured using the finest material available to provide long product life. Choosing the proper size ladder for location and correct fit is important to assure safe, convenient, and reliable use.

Although mounting hardware is not provided due to the wide variety of applications and diversity of boat shapes and sizes mounting holes have been provided and it is recommended to use a minimum 5/16" diameter fasteners. These fasteners should be through bolted with a backing plate.

SAFETY GUIDELINES

- No jumping or diving!
- Do not use when motor is running
- This ladder designed for boat use only
- Face ladder when entering boat or water
- Only one person on ladder at a time
- Check all steps and hardware before using
- Never operate your boat with the ladder in "down" position. Serious injury or damage to your boat or ladder may result.
 - **When underway, fold ladder up and insert back into tube ensuring locking pin snaps into place.**

MAINTENANCE

- **Safety tip**
Periodically check mounting hardware and re-tighten (due to normal boat operation.)
- **Keep that bright finish!**
Local weather conditions may contribute to minor corrosion. Stainless, like other metals, is not completely free from corrosion attack. Regular fresh water rinsing and periodic cleaning with a mild abrasive cleaner will help to retain luster.

Installation Instructions:

Note: Read all instructions completely before starting installation.

Step 1: Determine the correct location

Choose the most suitable side of your transom for mounting the ladder. Locate a flat surface [4 ½" wide x 5" high] where the ladder will not interfere with the turning of the motor or be excessively close to the propeller of your boat. Make sure that the location will be a minimum of 4" ABOVE the waterline at the bottom of the faceplate/assembly (see figure 1) and in an area where there are NO electrical wires, hydraulic hoses, water hoses or steering cables in the selected mounting location. In addition, check to see that the transom area is sufficiently strong enough to support the ladder while it is in use. If necessary, a backing plate may need to be installed to reinforce the area where the ladder is to be located [minimum thickness ¾"].

WARNING: If you have questions to the integrity of your boat or to the location of unseen equipment such as wiring or hoses then it is imperative that you contact the boat manufacturer prior cutting into your boat.

Figure 1: Location of ladder relative to actual water line.

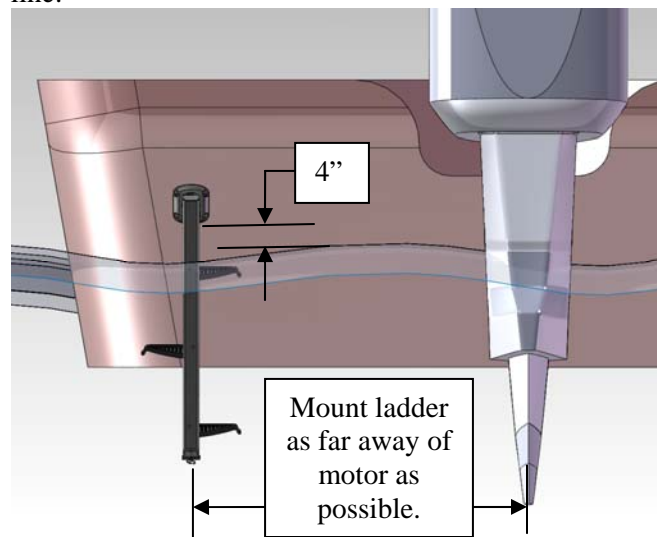

Write for
A complete
EEz-In Catalog

Garelick Mfg. Co.
644 2ND Street, P.O. Box 8
St. Paul Park, Minnesota 55071

Phone: 651-459-9795
E-mail: mail@garelick.com
Website: www.garelick.com

Rev A 08/11



Instructions for: 19700 SERIES INVISIBLE LADDER

12.627

The location to be used for mounting should be sufficiently flat and at a 13 degree angle in order to allow the ladder housing and ladder to function properly or a mounting shim may need to be fabricated and placed behind the ladder tube on the transom. Make sure that the boat will allow for a 3" hole to be bored into the transom at the desired mounting location PARALLEL to the waterline and that there is enough free length [35"] in the boat to receive the ladder tube.

Step 2: Mounting Instructions

Once the location has been determined, drill a 3" diameter hole in the transom; making sure that it is parallel to the waterline. Place the ladder assembly into the hole and mark the four faceplate mounting hole's locations. Drill the holes for appropriate 5/16" diameter hardware [not included]. It is preferred to through-bolt the assembly for a secure installation [use lock nuts and backing washers].

Caulk the entire area to be mounted [surfaces and hole sides] and insert the ladder, secure in place with the selected mounting hardware.

Secure the far end of the ladder to the boat with a strap or some other means to keep the ladder tube in place [not provided as all installations may vary].

Operating Instructions:

Grasp pull ring and pull down to release locking pin while pulling ladder assembly out until it stops. Then swing ladder down.

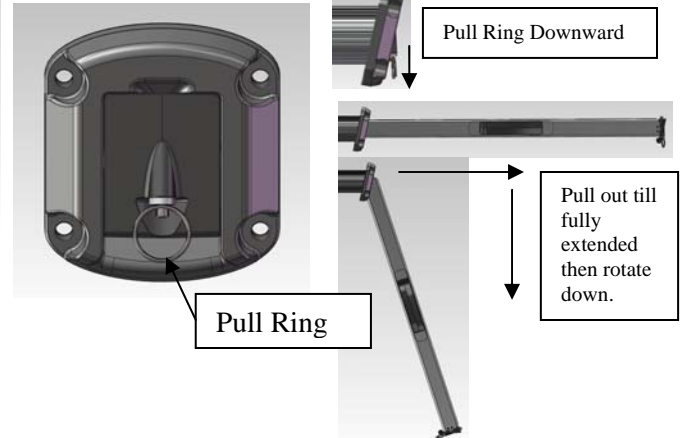
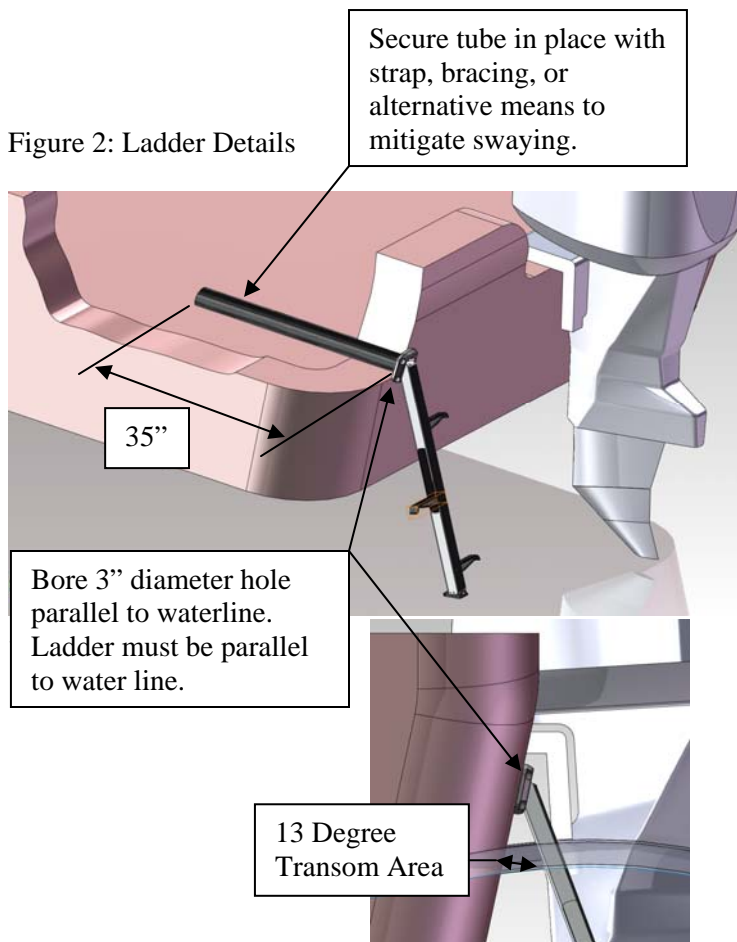

Pull out steps on the left and right and rotate them downward until they deploy fully.



Reverse process to store.

Write for
A complete
EEz-In Catalog

Garelick Mfg. Co.
644 2ND Street, P.O. Box 8
St. Paul Park, Minnesota 55071

Phone: 651-459-9795
E-mail: mail@garelick.com
Website: www.garelick.com

Rev A 08/11