



# Powered Auxiliary Outboard Motor Brackets Models 71095 and 71096

Thank you for choosing the Garelick/EEz-In Brand. The design/technology found in features of this product represent over 25 years of auxiliary outboard motor bracket experience and the fourth generation of brackets offered by our company to the boating public.

We are proud to manufacture this product to help you enjoy your time on the water. If you would like to comment on your experiences, please feel free to contact us by e-mail or write a letter to our Customer Service Center. When contacting us, please provide the serial number, which gives us the date of manufacture.

Transom Mounting Hardware **NOT** Supplied Due to Various Transom Thicknesses.

**Recommend 1/2" Stainless Steel Fasteners**

**SUPPLIED HARDWARE:**

Part No.	Quantity	Description
49.274	1 each	electrical harness with operating switch

**SPECIFICATIONS**

	H.P. Rating	Motor Weight Not to Exceed	Vertical Travel	Mounting Pad	Mounting Board Dimensions W x H x T	Mounting Bracket Dimensions W x H
<b>71095</b>	Up to 25	148 lbs.	13-1/4" (33 cm)	poly/alum	15-3/4" x 14" x 2" (40 x 35 x 5 cm)	12-1/4" x 8" (31 x 20 cm)
<b>71096</b>	25 to 40	248 lbs.	13-1/4" (33 cm)	poly/alum	15-3/4" x 14" x 2" (40 x 35 x 5 cm)	16-1/4" x 8" (41 x 20 cm)

Triple coat protective finish (anodized, E-Coat, powder coated).

**MOUNTING INSTRUCTIONS**

**Note:** The approximate vertical travel of the 71095/71096 Motor Brackets is 13". This travel is based on installation that's perpendicular to the water surface. The vertical travel will be less than 13" if the installation is on a positive angled transom, and will be more than 13" if installed on a negative angled transom. If your transom angle is more than 10° out of perpendicular, we recommend fabricating a wedged spacer out of a suitable material such as starboard, aluminum or finished hardwood to allow your installation to be perpendicular to the water surface. **Failure to follow these instructions can cause the actuator to retract below a horizontal position. This may cause the pump to draw air and fail to return to a stowed position.** The outside dimensions should be a minimum of 5-1/2" x 11-1/2", one for each mounting angle, or a single piece 11-1/2" x 20-1/2".

1. The Motor Bracket is shipped in the mid-stroke position. To complete installation, it is necessary to activate the Bracket to full down position. Set the Bracket on a flat surface. With a standard 12 volt battery, connect the green cable to the positive terminal and the blue cable to the negative terminal. This will cause the hydraulic cylinder to retract to

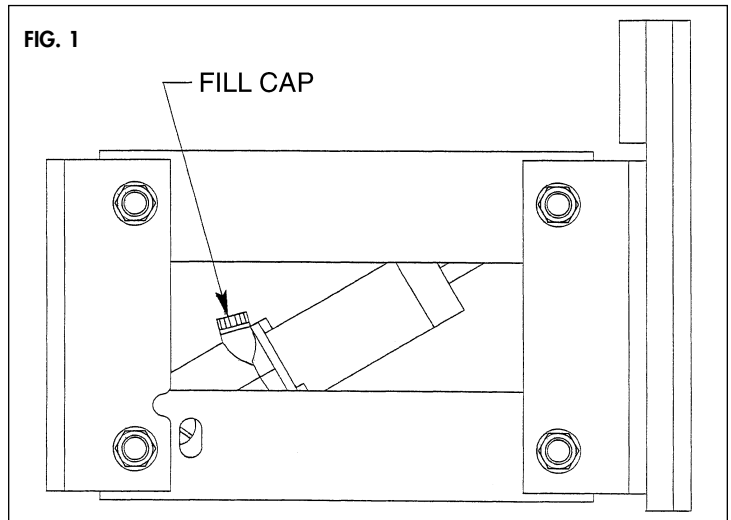

its shortest length or closed position. This is the full down position for the motor bracket. Disconnect the negative cable followed by the positive cable. (See Figures 1 and 2)

2. Measure the distance on your outboard motor between the cavitation plate and the upper inside edge of the mounting clamp. Cut a stick to this length and tape it to the mounting board with one end flush with the top of the board. (See Fig. 3)
3. Choose the most appropriate side of your transom for mounting the Bracket. Position your Bracket so it will not interfere with the turning operation of your main motor or rudder. Slide the Bracket up or down so that the bottom of the stick is approximately 1" or 2" below the bottom of the boat. Note: The bottom of the stick represents the cavitation plate on your outboard which must be below the boat's bottom for best performance. Make sure the bracket is parallel to the main power source or straight up and down left to right. Mark 4 mounting holes. Note: Gain access to the inside of the transom area where the installation is to be bolted through. Make sure the area is clear of any fuel or electrical lines. Because of the combined weight of the motor and Bracket, it is highly recommended that backing plates be used to help strengthen the installation. A minimum size of 3/4" thick, 4-1/2" wide and 10-1/2" long made from a marine grade plywood, aluminum or starboard, one for each mounting flange. (See Fig. 3)

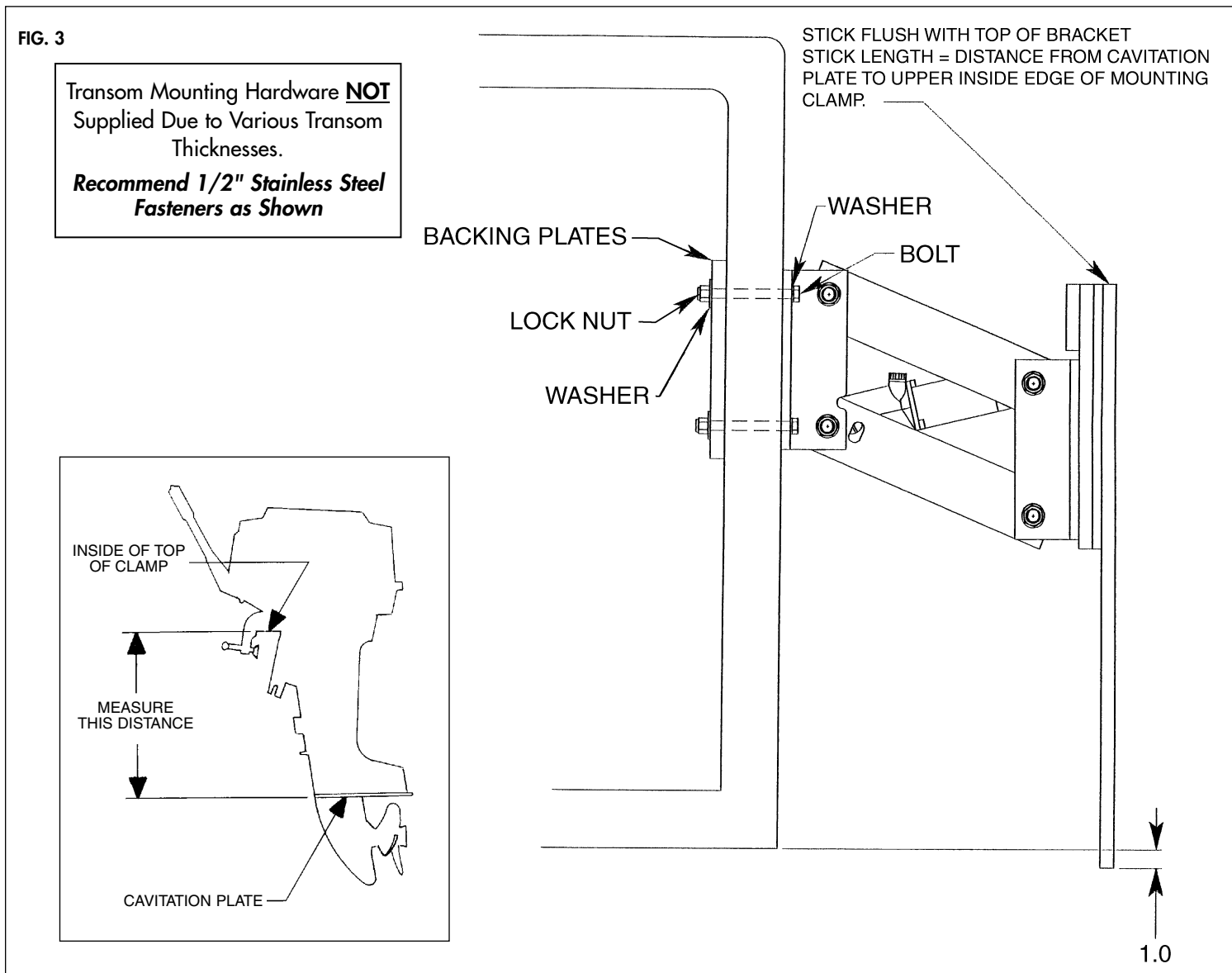
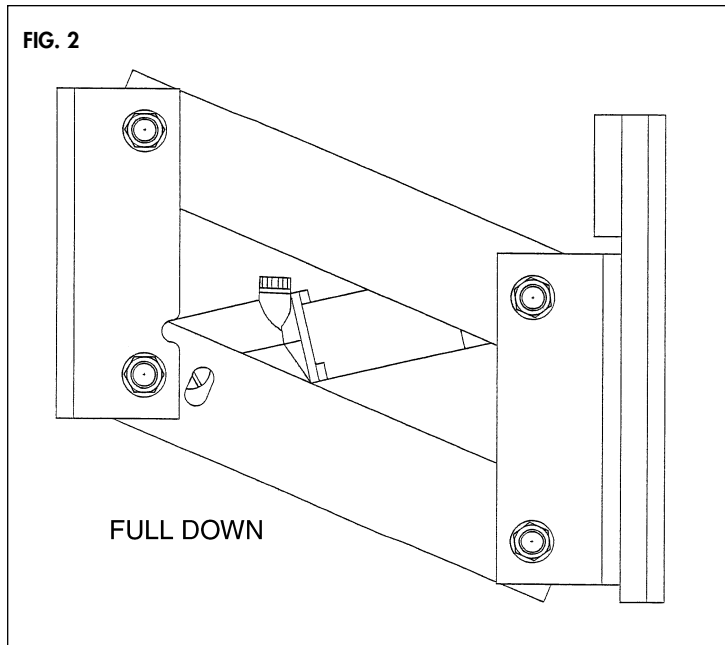

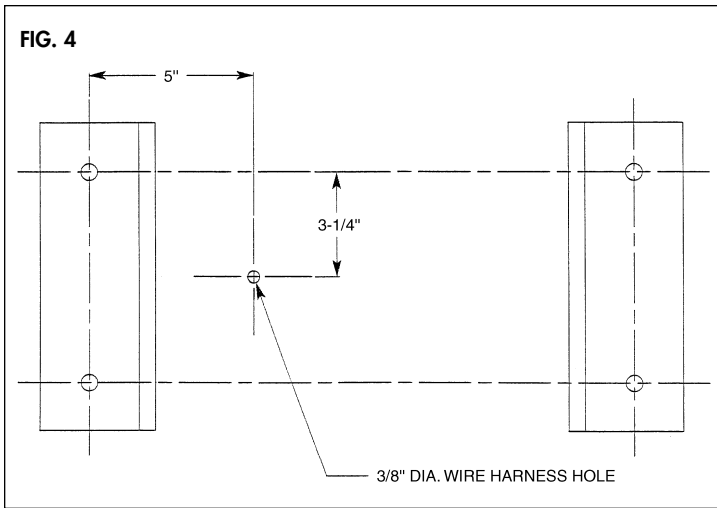

4. Drill 4 holes 17/32" diameter through transom. Make sure drill bit is held perpendicular to the transom when drilling. Drill one hole, 3/8" diameter in a suitable area between the four 17/32" diameter holes to route electrical wires from the actuator to the battery. (See Fig. 4)
5. Lay backing plates over mounting flanges so there is 1/2" or more of overhang on all 4 sides. Mark 2 holes on each backing plate and through drill 17/32" diameter. Make sure holes are drilled perpendicular to surface.
6. Attach the Motor Bracket to the transom after coating the inside surfaces of the mounting flanges and backing plates with a marine adhesive/sealant compound. Apply a small amount in each hole on both sides of the transom. Secure in place with supplied hardware. Insert cable from hydraulic actuator through 3/8" diameter hole in transom. Allow enough slack for operation of actuator and caulk cable in hole with marine grade silicone. (See Fig. 3)

7. **Electrical** Select a suitable place on the cockpit coaming to attach the activation switch. It is recommended that the switch be located in an area that allows a visual sight line to observe the Motor Bracket's motion when activated. The vertical surface selected should be accessible on the back side for routing electrical wires.

Scribe a 7/8" x 1-5/8" rectangle which will be clearance for the back side of the switch. Cut opening and feed plug end of switch cable through first. Align switch in opening with green wire on top. Mark four mounting holes, drill and fasten with suitable fasteners.

From inside the boat, connect the actuator cable leads to the relay cable leads. Connect black to blue and red to green. Route relay cable to battery area. Mount relay to suitable surface within 3 feet of battery.

Connect relay cable to switch cable by aligning 3 prong plug with 3 cavity plug and mating full closed. Route the flexible cable so it is not touching any hot surfaces or laying in water. Make final connection to battery. Connect red cable to positive (+) terminal on battery. Connect black cable to negative terminal (-). Test switch by pressing on top side of rocker button.

Bracket should come up. If bracket fails to rise, check all connections and check reset button on inline fuse at battery connection. Press on bottom side of rocker button and bracket will descend. (See Fig. 5.)

8. Mount outboard on Motor Bracket. Center motor left to right and clamp in place. It is recommended that 25 hp motors and larger be fastened in place with stainless steel bolts and locknuts of a suitable size as recommended by the manufacturer. Using the motor mounting bracket as a drill guide, through drill the mounting board and bolt in place. Check the location of the two lowest mounting holes on your outboard. If, when drilled, they are too close to the welded angle bracket on the opposite side to allow clearance for a bolt head or nut, then drill a suitable tap diameter hole, thread it and fasten with the bolt, eliminating the nut.

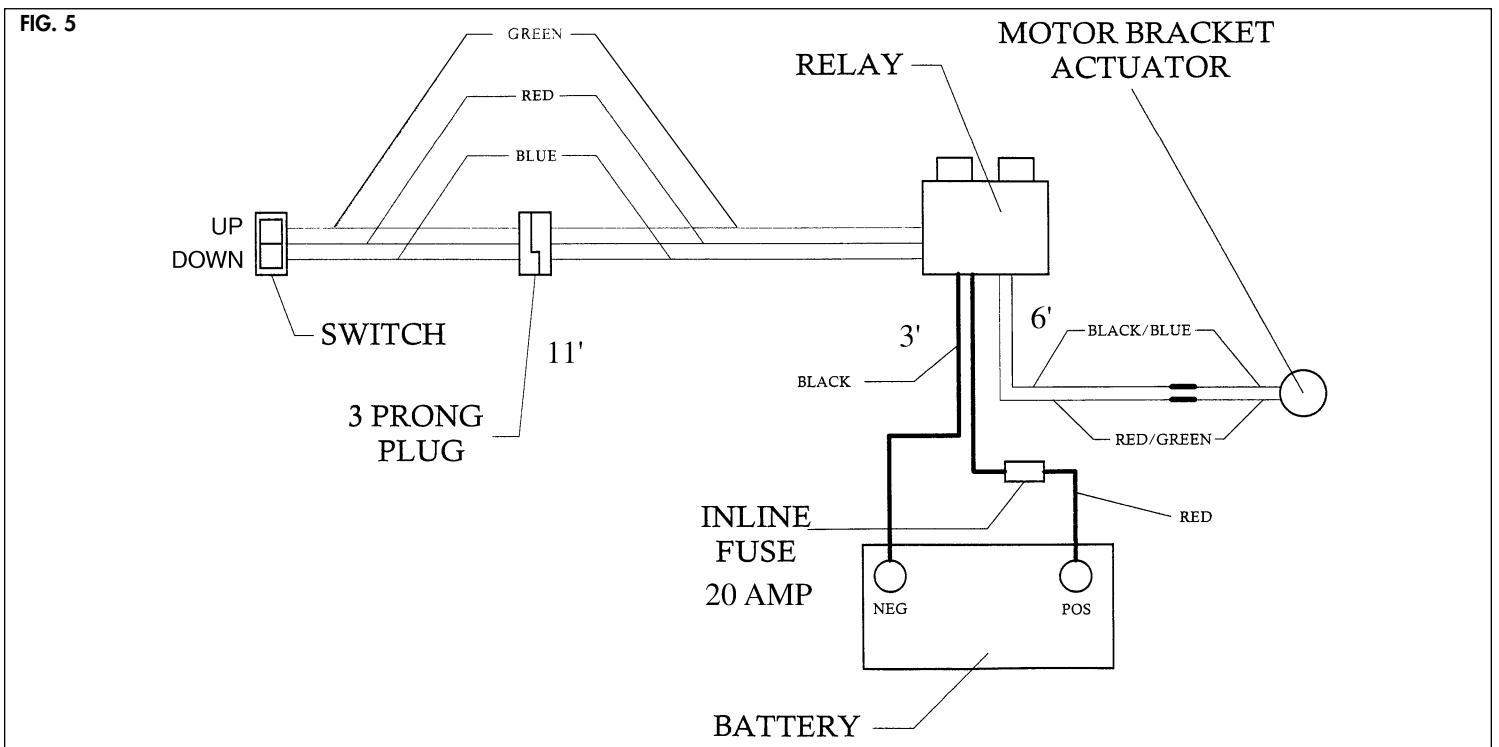

# Mounting and Operating Instructions – Powered Auxiliary Outboard Motor Brackets Models 71095 & 71096

## OPERATING INSTRUCTIONS

- Press and hold the “up” switch. The motor and Bracket should elevate and continue up until the actuator is fully extended. Release Switch Note: the “whine” of the actuator pump will change pitch when fully extended. Press and hold the “down” switch. The motor and Bracket should descend and continue until the actuator is fully retracted. Release the switch. The stowed position while underway with the main power is the full up position. If any part of the lower unit is still in the water with the bracket in the full up position, it is recommended that the motor be tilted to clear the water. Note: It is recommended that the bracket be in the full down position when using the auxiliary motor that is mounted on it.

### AUXILIARY OUTBOARD MOTOR BRACKET IMPORTANT CAUTION GUIDELINES

- Keep hands free of all moving parts.
- Do not exceed stated weight or horse power.
- Operate Bracket in lowest position possible for best performance.
- Operate motor at low speed.
- Do not turn motor full left or right at full throttle as the side forces could damage the Bracket and/or the boat transom.
- Always raise Bracket when not in use.
- Always be aware of the motor and bracket extending out the back of the boat when operating in and around decks, slips and other boats.
- Use of motor safety cable is highly recommended and comes standard with 71095 (up to 25 HP).

## SERVICE

To minimize wear, keep all 8 pivot points well lubricated with a medium to heavy lubricating oil/grease. In a salt water environment, it is recommended the bracket is periodically washed with soap and fresh water and waxed with a good grade marine polish/wax.

## MANUAL RELEASE VALVE

This Motor Bracket Actuator is equipped with a manual release valve. In an emergency, if the power source is unable to operate the actuator and the motor needs to be lowered to operating height, the manual release valve may be turned 3 to 4 turns counterclockwise and the bracket will lower itself. When Bracket is full down, the Manual Release Valve (A) must be turned clockwise until seated. (See Fig. 6)

FIG. 6

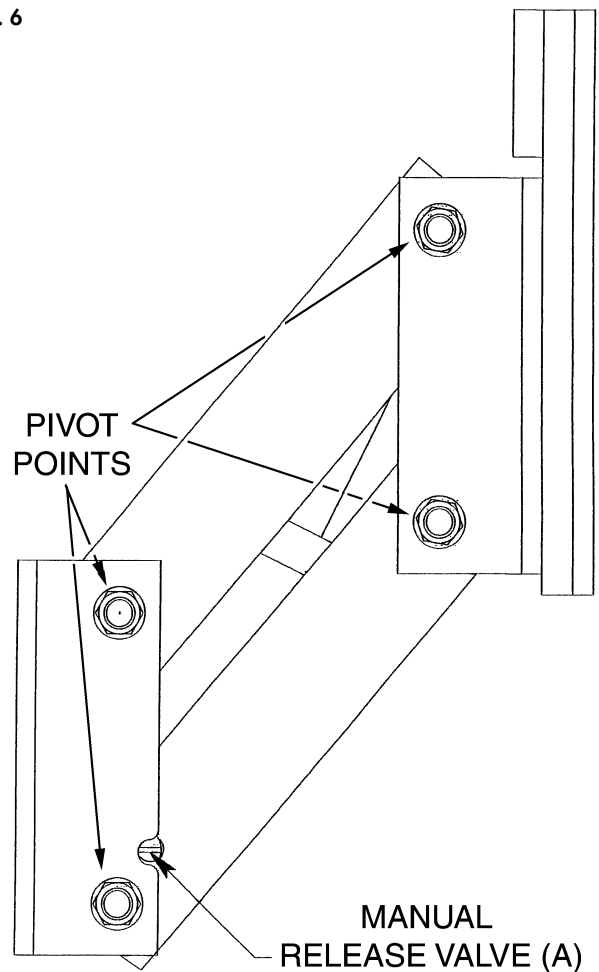

## CAUTION:

Do not apply electrical power to Bracket with manual release valve in the open position, as O-rings within the actuator will be damaged.

## BLEEDING THE ACTUATOR

The actuator is filled with Dextron 111 (ATF) at the factory and should not need periodic service. However, if the Bracket fails to stow in the full up position, it may be low on fluid. Lower the bracket to a position where access to the filler cap is available and remove the filler cap. Add Dextron 111 (ATF) if available, or Quicksilver Power Trim and Steering Fluid, approximately 1 oz. at a time, to reduce the chance of over filling. **Leave the filler cap off to allow any over fill to escape. Failure to follow these instructions could cause permanent damage to the seals in the actuator.** (Use appropriate means to protect the environment and capture any over flow.) Cycle the bracket several times and repeat if necessary. Replace and tighten filler cap when finished (See Fig. 1 and 6).