

INSTALLATION INSTRUCTIONS FOR SPORT/DIVER LADDERS

Thank you for selecting our superior quality Garelick EEz-In Board Boarding Ladder. Your ladder was designed and manufactured using the finest material available to provide long product life, all fabricated and finished with boating in mind. Choosing the proper size ladder for location and correct fit is important to assure safe, convenient, and reliable use.

ASSEMBLY INFORMATION

- Read these instructions completely before starting assembly.

REQUIRED HARDWARE

NOTE: The following parts are not included due to the variety of possible installations.

- 4 Suitable length 5/16-18 stainless steel bolts

NOTE: Bolts should be at least 1 1/4" longer than transom and backing plate thickness.

- 4 Suitable stainless steel backing washers

- 4 5/16-18 stainless steel lock nuts

- Marine adhesive/sealant and anti-seize compound

- Backing plate (minimum size 4" x 5 1/2") of suitable material

TRANSOM OR EXTENSION BRACKET MOUNTING

1. Choose the most suitable side of transom for mounting ladder.
2. Locate a place on the transom where the ladder will mount and not interfere with the turning and lowering operation of your motor. Determine the actual waterline when the boat is at rest. Mark this location in both the horizontal and vertical direction.
3. Locate the ladder on this mark and slide it up to the desired mounting height. Keep in mind that it is optimal to have at least two steps in the water for ease of boarding. Mark the ladder's position at the top mounting bolt.
NOTE: This line will locate the top two holes for the mounting plate.

4. Check the inside of the transom where the mounting is proposed. Verify that there is ample space to install a backing plate (minimum size 4" x 5 1/2") that will support the ladder installation. A 4" x 5 1/2" minimum flat area or the size of your backing plate is required for a secure installation.

NOTE: The backing plate should be made of either aluminum, marine plywood or some other suitable non-compressive material.

5. Mark four mounting plate hole locations on your transom or transom extension bracket using the plate as your template.

NOTE: It may be necessary to make an external shim or modify the mounting substrate to achieve the proper ascent angle (5 to 10 degrees) for your ladder. Drill one 11/32" or 3/8" hole through your transom, noting the angle of the mounting substrate hole angle. These holes are perpendicular to the mounting face plate, not the transom. When drilling, this hole angle should be used to insure a proper installation. Place the mounting substrate and faceplate against the boat and loosely mount it with the hardware that you have selected for proper installation.

6. Level the bracket, mark and drill the next hole. Check the ladder for level, make adjustments if necessary and then, drill the other two holes.
7. Loosen the mounting faceplate enough to install roll pin into the mounting substrate as illustrated. Place the locking bar into the substrate.

NOTE: The notch in the bar faces down as shown. Slide the locking bar's operation to insure it slides back and stops.

8. Put a bead of adhesive caulk around the perimeter of the mounting holes and all edges of the mounting substrate, coat the bolt threads with anti-seize compound and secure the mounting substrate in place by tightening all four mounting bolts.
9. Mount securing clips at desired location as illustrated with selected stainless steel hardware. Note the illustration's suggestion for placement of hardware. This will insure that the ladder will not rotate or slide when boat is underway.

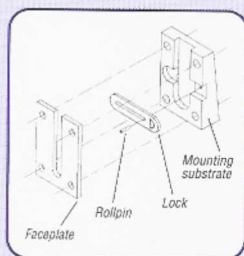
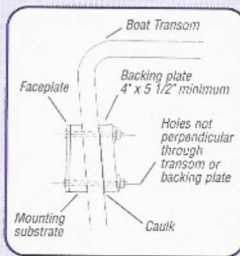
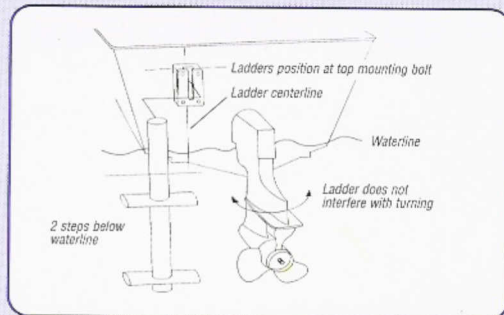

LADDER OPERATION INSTRUCTIONS

1. Always lock the ladder when it is in use with the lock bar.
2. Never operate your boat with the ladder in the "down" position. Serious injury, or damage to your boat or ladder may result.

SAFETY GUIDELINES

- No jumping or diving!
- Do not use when motor is running
- This ladder designed for boat use only
- Face ladder when entering boat or water
- Only one person on the ladder at a time
- Check all steps and hardware before using

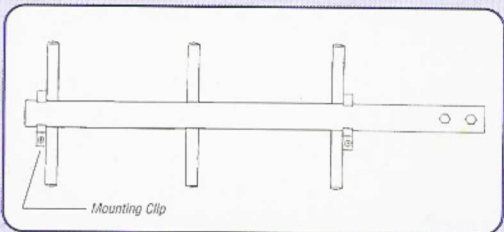

Garelick Mfg. Co.

644 Second Street, P.O. Box 8

St. Paul Park, MN 55071

Phone: (651) 459-9795 • Fax: (651) 459-8269

www.garelick.com