

ASSEMBLY INFORMATION

1. Read instructions completely before starting assembly.
2. For product integrity during shipment, your slide has been secured with a transit screw. Remove screw prior to assembly.

ASSEMBLY INSTRUCTIONS

Refer to Fig. 1

1. Slide the track plate (A) out of the swivel base as shown.

Refer to Fig. 2

1. Position the track plate (A) on your seat's bottom.
2. Align the holes in both the seat and track plate. Secure the track plate to your seat with appropriate hardware. NOTE: Fastener suggestion is illustrated, fasteners are not provided. NOTE: All EEz-In seats use 1/4"-20 threaded T-nuts.

Special NOTE: For Rotational Molded EEz-In Seats. When attaching a slide to an EEz-In Rotational Molded Seat:

1. Remove the reinforcement brackets from the seat bottom prior to installation.
2. Make certain that the portion of the screw entering the seat shell's T-nut does not exceed 3/8". Seat shell T-nuts are 1/4"-20 thread. Use only 1/4"-20 machine screws.

Refer to Fig. 1

1. Slide track plate (A) with seat onto the swivel base. Position the system where it is to be mounted. Check to see that the seat will slide and rotate where it is located. NOTE: This swivel system is designed to rotate with a person seated in it. For this reason, it will not turn easily by hand. It is recommended that one side of the swivel is clamped or held in place in order to rotate the swivel when it is not mounted.
2. Mark and drill the four swivel base mounting hole locations on the deck where the system is to be mounted.
3. Make sure the deck is sufficiently rigid to support this load. If it is not, this area should be adequately reinforced. Use a backing plate if necessary to make a secure attachment. It is recommended that the fasteners used go through both deck and backing plate. Washers and locking nuts should be used to secure this system in place. Four holes are drilled in the base for attachment but fasteners are NOT provided for this application as the type needed may vary.

Refer to Fig. 3

1. Slide the seat and track plate off of the swivel base.
2. Lift the locking handle (B) on the swivel base and move it to the right or left. This will disengage the locking pin.
3. Rotate the swivel plates as shown to reveal the mounting holes. NOTE: It is recommended to clamp one side of the swivel in order to facilitate turning.
4. Secure the swivel base in place using appropriate hardware. NOTE: These mounting holes are 19/64" in diameter. It is recommended to through bolt this system in place.

Refer to Fig. 1

1. Slide the seat and track plate (A) back onto the swivel base as shown.
2. Align the holes in the locking nut (C) and slide plate. NOTE: Align the holes in the locking nut and poly sleeve if necessary.
3. Slip the stainless steel washer (D) onto the locking knob (F) as shown. Insert the locking knob into the slide plate's hole and thread it into the locking nut (C). Secure the slide in position.

TO OPERATE

Sliding: Loosen the locking knob and slide the seat to the desired position. Tighten the handle to secure the slide in place.

Swiveling: Lift the locking handle and rotate the seat. Let go of the handle and the seat will lock in the next available locking hole. Locking holes are set at 45° increments. If it is desired to have free swiveling, simply lift the locking handle and move it to the left or right. This will keep the pin from engaging the locking holes.

NOTE: Locking knob "F" must be secured tightly before motoring.

FIG. 1

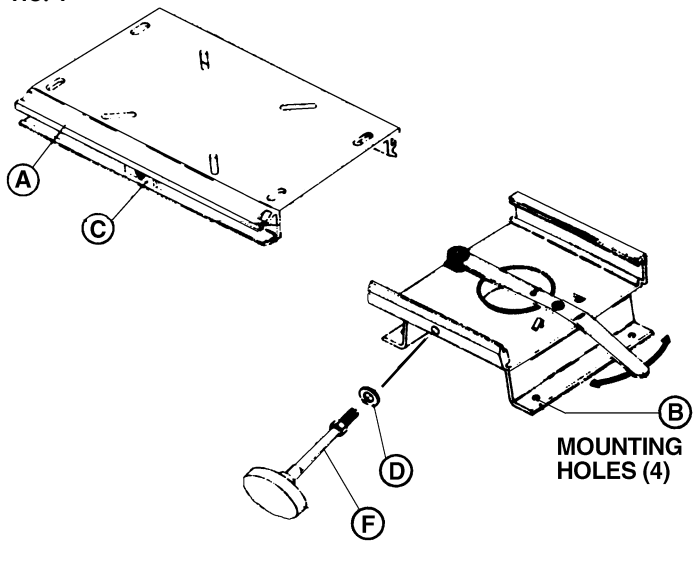

FIG. 2

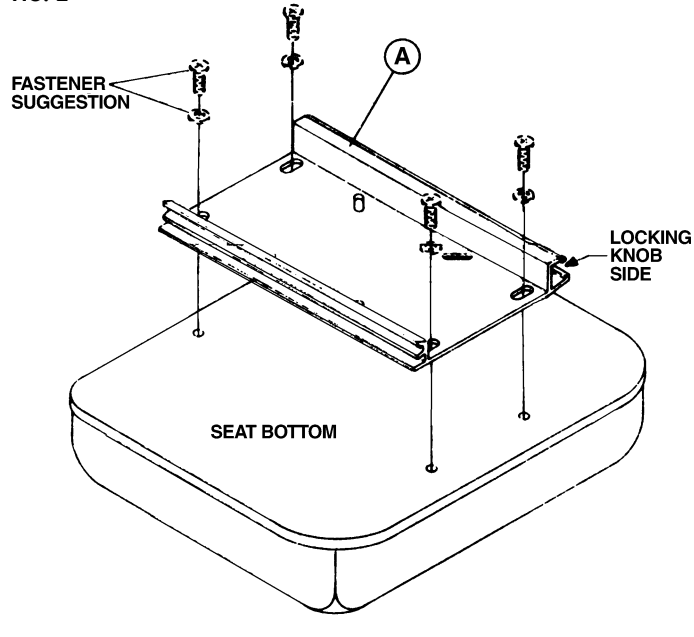

FIG. 3

