



Stationary Outboard Motor Bracket

ASSEMBLY INSTRUCTIONS

Refer to Fig. 1

1. Attach mounting board (A) to brackets (B) by inserting elevator bolts (C) through the board's top two holes. Secure with washers (D) and nuts (E). Finger tighten only.
2. Slide carriage bolts (F) through the board and bracket holes as illustrated. Secure with washers (D) and nuts (E).
3. Secure the board in place by tightening all four fasteners.

MOUNTING INSTRUCTIONS

Refer to Fig. 2

1. Measure the distance on your outboard motor between the cavitation plate and the upper inside edge of the mounting clamp. Subtract 2" from this length. This is the maximum height that your bracket should be mounted above your boat's ACTUAL waterline.

Refer to Fig. 3

2. Position your bracket so it will not interfere with the turning operation of your main motor or rudder. Mark the four hole locations using the bracket as a template.
3. Drill the four marked holes with a 3/8" bit, making sure to hold the drill at right angles to the transom.
4. If your transom is less than 2" thick, it is recommended that a backing plate be made and mounted on the inside of the transom for needed rigidity. Attach your motor bracket to the transom by coating the inside surfaces of the mounting flanges and backing plate with a marine adhesive/sealant compound and then squeeze a small amount into each bolt hole on both sides of the transom. Secure the bracket to the transom. The bracket is now ready for mounting.

IMPORTANT RECOMMENDATIONS

1. THIS BRACKET IS NOT RECOMMENDED FOR USE WITH 4-STROKE OUTBOARD MOTORS.
2. REMOVE YOUR MOTOR FROM THE BRACKET WHEN TRAILERING YOUR BOAT.
3. USE A MOTOR SAFETY CABLE TO SECURE THE MOTOR TO THE BOAT.
4. PERIODICALLY, CHECK FASTENERS FOR TIGHTNESS.

Transom Mounting Hardware **NOT** Supplied Due to Various Transom Thicknesses.

Recommend 5/16" Stainless Steel Fasteners

Parts List

Ref. Letter	Factory Part No.	No. Req.	Description
A	06.322	1	Mounting board
B	57.066	2	S.S. mounting bracket
C	03.158	2	5/16"-18 x 2 1/2" s.s. elevator bolt
D	03.157	4	5/16" s.s. lockwasher
E	03.020	4	5/16"-18 s.s. nut
F	03.244	2	5/16"-18 x 2 1/2" s.s. carriage bolt
I	03.030	2	s.s. pronged washer

FIG. 2

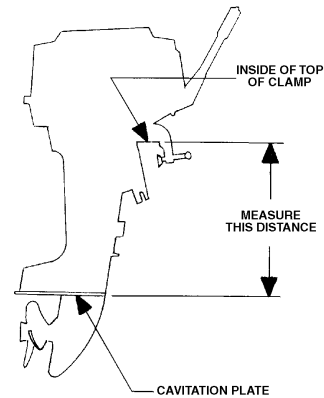
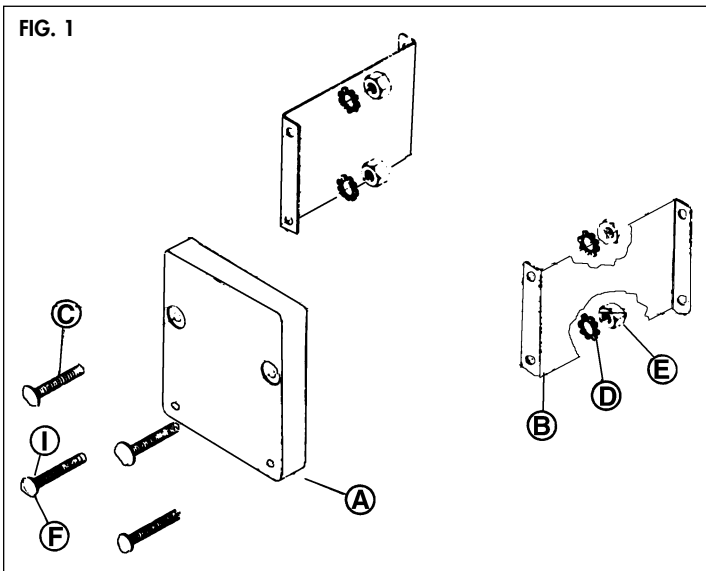
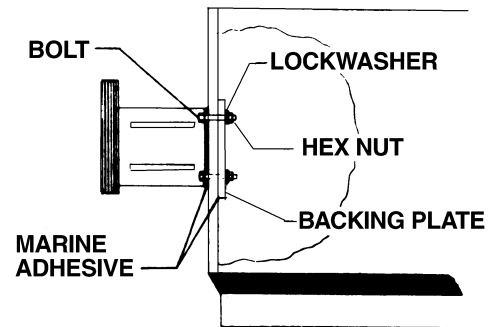

FIG. 3



Write for a Complete Ez-In Catalog

GARELICK
PO Box 8, 644 2nd Street
St. Paul Park, Minnesota 55071

Phone: 651-459-9795
E-mail: mail@garelick.com
On the Web: www.garelick.com