



Mounting Instructions for Rotational Molded Poly Seats

Form 12.131

SWIVEL CASTING ATTACHMENT

Mount Swivel Casting to Reinforcement Brackets by inserting 1/4-20 x 1" Screws (A) through Washers (B), Swivel Casting and Brackets as shown. Secure with Washers (B) and Locknuts (C). **FINGER TIGHTEN ONLY.** Make certain Swivel Casting's Locking Rod is directed to side of Seat.

Mount Reinforcement Brackets with Swivel Casting to Seat Bottom with 1/4-20 x 1/2" Screws (D) and tighten.

Using an open-end wrench and phillips-head screwdriver, finish securing Swivel Casting to Brackets.

SEAT SLIDE ATTACHMENT

Attach the slide by aligning the matching holes in the seat

bottom; secure with appropriate 1/4-20 machine screws. NOTE: The portion of the screw entering the seat should not exceed 3/8 inch.

GIMBAL ATTACHMENT

When mounting an EEz-In Model 75011 gimbal to seat, use the T-nutted holes as illustrated and attach gimbal with 1/4-20 x 1/2" machine screws.

CARE AND MAINTENANCE

This rotational molded poly seat and cushions can be cleaned with mild soap and a non-abrasive sponge or cloth. Periodically tighten screws on seat bottom.

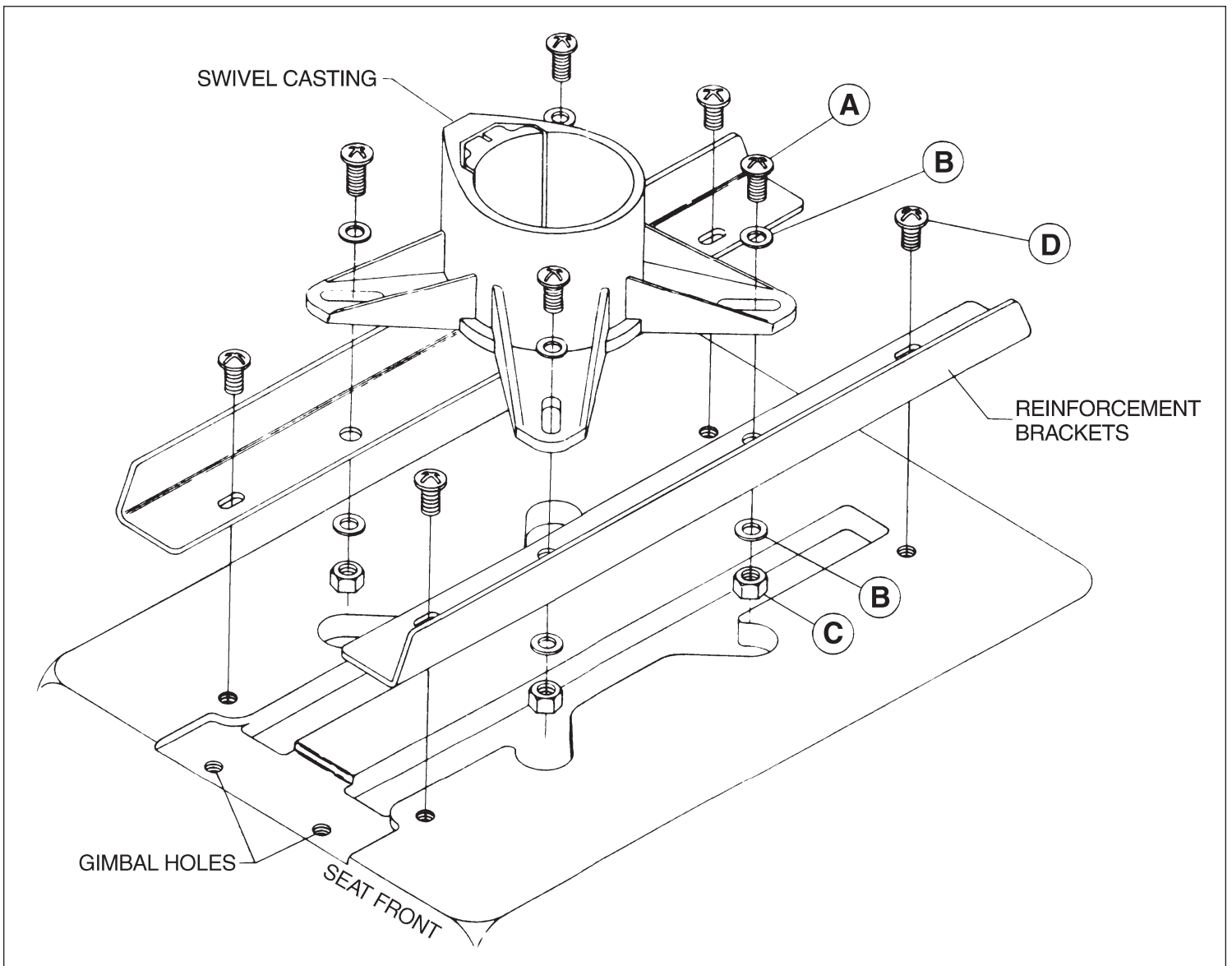

Write for
a Complete
EEz-In Catalog

GARELICK
PO Box 8, 644 2nd Street
St. Paul Park, Minnesota 55071

Phone: 651-459-9795
E-mail: mail@garelick.com
On the Web: www.garelick.com